

# AMN7100

Lambda Terminal

## General Description

The AMN7100 Lambda Terminal is a compact, multi-faceted product designed to enhance the features and functionality of Hitachi's AMN 6100 DWDM system or as a standalone product to enhance other vendors' DWDM systems. The AMN7100 provides interfaces required for 10 Gb/s lambda services. In addition, the micro-Transmux feature of the AMN7100 provides 1Gb Ethernet or 2.5 Gb/s lambda services by performing SONET muxing up to 10Gb/s channel rate to maximize the DWDM traffic carrying capacity. An optical switch fabric option provides per channel protection for client service inputs to the AMN7100. The Coarse WDM feature of the AMN7100 provides metro-haul capabilities for up to 8 channels, which allows the customer to extend the long haul DWDM backbone to customer sites or carrier remote sites that are up to 40km from main backbone POPs.

## Advanced Features and Advantages

- Line signals formatted to ITU-G.709 Optical Transmission Network (OTN) format
- High speed Transponder for 10 Gb/s channel services
- Regeneration of 10.7 Gb/s WDM channels in long haul networks
- DWDM channel capacity maximized by multiplexing 1GbE and 2.5 Gb/s (OC-48/STM-16) client services to 10 Gb/s or 10.7 Gb/s DWDM inputs

- Optical switch for 1:N/1+1 facility protection
- Coarse WDM metro haul applications
- Patented Transparent Transport (patent pending) of tributary signals to support existing OC-48 rings and other independent customer network communications
- Integrated Forward Error Correction (FEC) supports improved error rate services and extended DWDM span distances
- Modular single shelf system supports 11 function cards per shelf (micro-Transmux , Transponder, Regenerator, Optical Selector Switch, CWDM)
- Three shelves per 7' bay (12" depth)
- Regenerators or any custom combination to provide 110 Gb/s per shelf (330 Gb/s per bay)
- Comprehensive network management
- Flexible synchronization capability for the micro-Transmux (external clock, line time, internal clock)
- Orderwire and Housekeeping alarm/control

## Comprehensive OAM&P

The AMN 7100 supports TL-1/TCP-IP management interfaces between the NEMS/GLCT and the NE. The Hitachi EMS provides a centralized and robust environment for management and control. These elements support alarms and performance monitoring for both SONET/SDH and ITU OTN functions.

# AMN7100

## Lambda Terminal

### Specifications

#### Transponder (max. 11 units per shelf)

Transmission Rate:	10.7 Gb/s
Optical Line Wavelengths:	ITU Grid 100/50 Ghz spacing C band, L band
Optical Line Signal Format:	ITU G.709 wrapper
Client/Tributary Side Signal Rate:	9.953 Gb/s
Client/Tributary Side Optical Wavelengths:	1550 nm
Client/Tributary Side Signal Format:	SONET/SDH OC-192/STM-64

#### Regenerator (max. 10 units per shelf)

	(unidirectional)
Transmission Rate:	10.7 Gb/s or 10 Gb/s
Optical Line Wavelengths:	ITU Grid 100/50 Ghz spacing C band, L band
Optical Line Signal Format:	ITU G.709 wrapper
Input Signal Rate:	10.7 Gb/s
Input Optical Wavelengths:	Wideband C Band, L Band
Input Signal Format:	ITU G.709 Wrapper

#### Micro-Transmux (max. 11 units per shelf)

Transmission Rate:	10.7 Gb/s or 10 Gb/s
Optical Line Wavelengths:	ITU Grid 100/50 Ghz spacing C band, L band
Optical Line Signal Format:	ITU G.709 wrapper
Client/Tributary Side Signal Rate:	1Gb Ethernet
Client/Tributary Side Signal Rate:	2.488 Gb/s
Tributaries (Input):	1Gb Ethernet
Tributaries (Input):	OC-48/STM-16
Client/Tributary Side Optical Wavelengths:	1310 nm, 1550 nm
Client/Tributary Side Signal Format:	SONET/SDH (OC-48/STM-16)
Client/Tributary Side Signal Format:	1Gb Ethernet

#### Coarse WDM (max. 8 wavelengths per shelf)

Transmission Rate:	10Gb/s (+/- 7nm tolerance)
Optical Line Rate:	1471nm, 1491nm, 1511nm, 1531nm, 1551nm, 1571nm, 1591nm, 1611nm
Optical Line Signal Format:	ITU G.709 wrapper
Single Mux Card:	Combines 8 wavelengths
Single Demux Card:	Separates 8 wavelengths
Low Insertion Loss for Mux/Demux Combination:	3db

#### Optical Switch Fabric

1+1 line protection for 10Gb/s channels

#### DC Power

Input:	-42.5 V to -56 VDC
Consumption:	1000 Watts/shelf max.

#### Operating Environment

Temperature:	5°C ~ 38°C (41°F to ~ 100°F) - Normal operation -5°C ~ 50°C (23°F to ~ 122°F) - Short term operation
Humidity:	20% to 55% - Normal 20% to 80% - Short term

#### Physical

Shelf Dimensions:	23" (w) x 23.6" (h) x 11.8" (d) {584.2mm x 600mm x 300mm} Includes fans, filter and connector-control/display panel
Shelves Per Bay:	max.3 in a 7ft NEBS Bay
Optical Connectors:	SC/LC
OSS, Craft Connectors:	RJ-45 (Ethernet)/ RS-232
Alarm/Control/OW:	DSUB

#### Supervisory and Control Interfaces

OSS:	TL-1/TCP-IP/802.3
Local Craft/Remote Craft:	TL-1/802.3, TL-1/RS-232
Modem:	TCP/IP, PPP/RS-232
Housekeeping Alarms:	32 photocoupler
Housekeeping Controls:	16 Form C relay contacts
Orderwire:	Analog
Timing:	Through Timing (Transponder/ Regenerator), BITS DS-1(Micro- Transmux) External Timing, Line Timing in Freerun (Micro-Transmux) Internal - Stratum 3

### AMN 7100 and DWDM Network

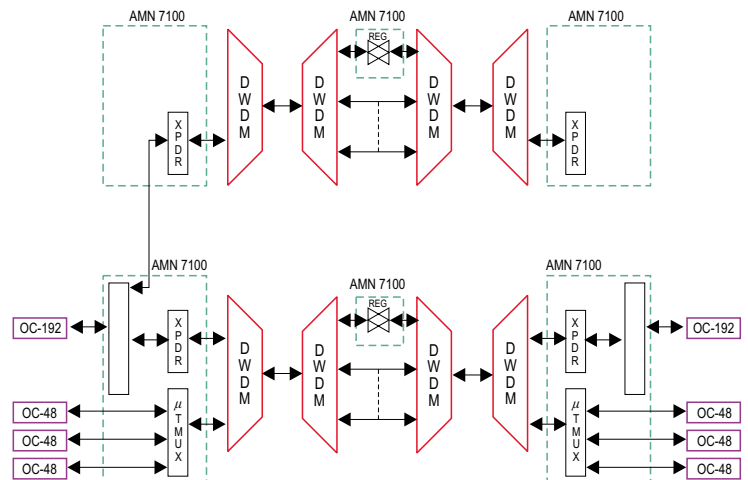

**HITACHI**  
Inspire the Next  
Optical Solution

Hitachi Telecom (USA), Inc. ■ 3617 Parkway Lane ■ Norcross, GA 30092 ■ 1-800-446-8820 ■ <http://www.hitel.com>

Though this document was believed to be correct at the time of publication, Hitachi Telecom (USA), Inc., Hitachi America, Ltd. and their affiliates assume no responsibility for errors or omissions. Features and specifications subject to change without notice.